

Harvard CS121 and CSCI E-207

Lecture 1: Introduction and Overview

Harry Lewis

September 2, 2009

Introduction to Formal Systems and Computation

Computer Science 121 and CSCI E-207

Objective:

Make a *theory* out of the idea of *computation*.

What is “computation”?

“Processing of information based on a finite set of operations or rules.”

- Paper + Pencil Arithmetic

$$\begin{array}{r} 121 \\ + 99 \\ \hline 220 \end{array}$$

- Abacus
- Calculator w/moving parts (Babbage wheels, Mark I)
- Ruler & compass geometry constructions
- Digital Computers

Further computing devices

- Programs in C, Java.
- The Internet and other distributed systems.
- Cells/DNA?
- The human brain?
- Quantum computers?

What do we want in a “theory”?

- **Generality**
 - Technology-independent
 - Abstraction: ignores inessential details
- **Precision**
 - Mathematical, formal.
 - Can *prove* theorems about computation, both positive (what can be computed) and negative (what cannot be computed).

Representing “Information”

- Alphabet

Ex: a, b, c, \dots, z .

- Strings: finite concatenation of alphabet symbols, order matters

Ex: $qaz, abbab$

ε = empty string (length 0; sometimes e)

- Inputs (& outputs) of computations are strings.

\Rightarrow we focus on *discrete* computations

Computational Problems (i.e. Tasks)

A single question that has infinitely many different instances

- *PARITY*: given a string x , does it have an even number of a 's?
- *MAJORITY*: given a string x , does it have more a 's than b 's?

Examples of computational problems on numbers

- *ADDITION*: given two numbers x, y , compute $x + y$.
- *PRIMALITY*: given a number x , is x prime?

Examples of computational problems about computer programs

- *C SYNTAX*: given a string of ASCII symbols, does it follow the syntax rules for the C programming language?
- *HALTING PROBLEM*: given a computer program (say in C), can it ever get stuck in an infinite loop?

Computational problems from pure and applied mathematics

- *DIOPHANTINE EQUATIONS*: Given a polynomial equation (e.g. $x^2 + 3xyz - 44z^3 = 0$), does it have an integer solution?
- *TRAVELLING SALESMAN PROBLEM*: Given a set of ‘cities’ in the plane, what is the fastest way to visit them all?

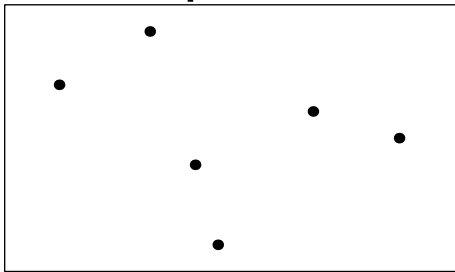

- *GRAPH 2-COLORING (3-COLORING)*: Given a set of people, can they be partitioned into 2 groups so that every pair of people in each group gets along? (3 groups?)

More examples of computational problems

- *REGISTER ALLOCATION*
- *MULTIPROCESSOR SCHEDULING*
- *PROTEIN FOLDING*
- *DECODING ERROR-CORRECTING CODES*
- *NEURON TRAINING*
- *AUCTION WINNER*
- *MIN-ENERGY CONFIGURATION OF A GAS*
- ...

The (Mathematical) Idea of a Language

- A **language**: any set of strings.
- “Solving a yes/no computational problem”
⇔ “Deciding if a string is in a given language”

Examples of Languages

- All words in the *American Heritage Dictionary*

$\{a, aah, aardvark, \dots, zyzzyva\}$

Mathematically simple, because it's finite!

- All strings with an even number of a 's.

$\{\varepsilon, b, bb, aa, baa, aba, baa, \dots\}$

Note: “ ε ” denotes the string of length 0 – the empty string

Infinite – but simple membership rule

- All syntactically correct C programs

(counting space and newline as characters)

Computational Models

What is a computer? First try: a mathematical automaton.

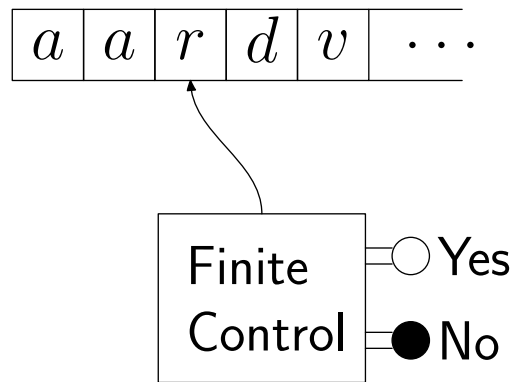

We don't care how the control is implemented – only that it have a finite number of states and change states based on fixed rules

Kinds of Automata

Finite Automata

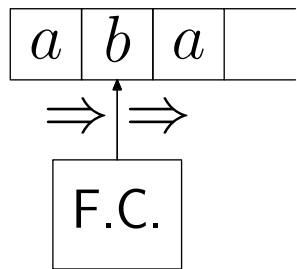

- Head scans left to right
- Check simple patterns
- Finite Table Lookup
- Can't count without limit

Pushdown Automata

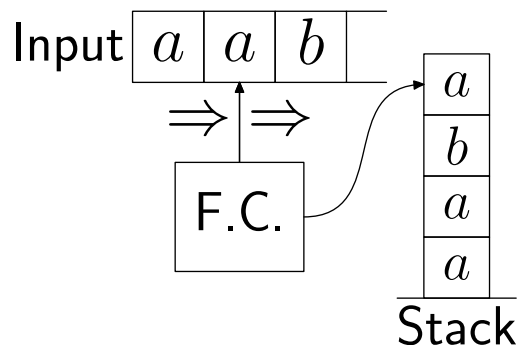

- Use stack to count, balance parentheses
- Check many syntax rules

A model for general-purpose computers

Turing Machines

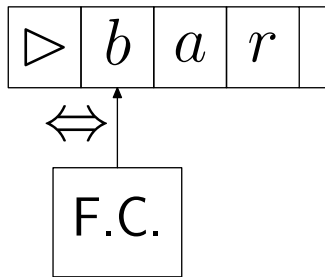

- Control is still finite
- Head moves left and right, reads, and writes

Q1: What computational problems can be solved by these automata?

- Finite Automata: the **regular languages**. A FA can determine whether or not strings are “generated” by any fixed *regular expression*, e.g.

a^* generates $\{\varepsilon, a, aa, aaa, \dots\}$

* = “any number of”

$(ab)^*$ generates $\{\varepsilon, ab, abab, ababab, \dots\}$

$(a^*ab)^*a^*$ generates $\{???\}$

Models

Pushdown Automata: the **context-free languages**. A PDA can determine whether or not strings are generated by any fixed *context-free grammar*, e.g.

$$\left\{ \begin{array}{l} S \rightarrow aSb \\ S \rightarrow \varepsilon \end{array} \right\} \text{ generates } \{\varepsilon, ab, aabb, aaabbb, \dots\}$$

Note: this is not the same as a^*b^* !

$$S \Rightarrow aSb \Rightarrow aaSbb \Rightarrow aabb$$

CFGs as models for natural languages

$$\left\{ \begin{array}{l} \langle \text{sentence} \rangle \rightarrow \langle \text{noun - phrase} \rangle _ \langle \text{verb} \rangle \\ \langle \text{noun - phrase} \rangle \rightarrow \langle \text{noun} \rangle \mid \langle \text{adjective} \rangle _ \langle \text{noun - phrase} \rangle \\ \langle \text{noun} \rangle \rightarrow \text{cat} \mid \text{dog} \mid \text{mouse} \\ \langle \text{adjective} \rangle \rightarrow \text{black} \mid \text{hungry} \\ \langle \text{verb} \rangle \rightarrow \text{jumps} \mid \text{barks} \end{array} \right.$$

generates {black_dog_jumps, hungry_black_cat_barks, ...}

More powerful models

- Turing machines: the **computable languages**
 - Captures our intuitive notion of “computable” (**Church–Turing Thesis**).
 - TMs equivalent in expressiveness to C programs, LISP programs, Pentium CPU, (hypothetical) quantum computers, ...
 - Concept of computability is independent of technology!

Church's Thesis (Church-Turing Thesis)

Intuitive notion of “computable”

≡

Formal notion of “computable
by a Turing Machine”

Are there non-computable languages?

Yes – in fact “almost all” languages are not computable

What are some examples?

[Problems to avoid!]

Q2: Are there computational problems that cannot be solved by these automata?

- Yes — in fact “almost all” problems are not computable.
- But what are some examples? [Problems to avoid!]
- A non-regular problem?
- A non-context-free problem?
- Non-computable problems?

Classifying languages

	FA/ regular?	PDA/ context free?	TM/ computable?
<i>PARITY</i>			
<i>MAJORITY</i>			
<i>PRIMALITY</i>			
<i>C SYNTAX</i>			
<i>HALTING</i>			
<i>TSP</i>			
<i>2-COLORING</i>			
<i>DIOPHANTINE EQ.</i>			

Q3: Are there computable problems that cannot be solved efficiently?

- A problem need not be uncomputable to be practically unsolvable (It may just take too long!)
- Theory of relative difficulty of problems
 - Based on resources required:
 - Time
 - Memory
 - ...

The NP-Complete Problems

*TRAVELLING SALESMAN PROBLEM, GRAPH
3-COLORING, MULTIPROCESSOR SCHEDULING,
PROTEIN FOLDING, ...*

Do they have efficient algorithms? Either all do or none do!

This is the famous (and still open) **P vs. NP Question**.

More NP-Complete Problems

- Integer Linear Program

Is there a solution over the positive integers to a system like this?

$$\begin{array}{rclclcl} x_1 & - & 4x_2 & + & x_3 & = & 0 \\ x_1 & + & x_2 & + & x_3 & \leq & 0 \\ x_1 & & & + & 7x_3 & \geq & 0 \end{array}$$

- Boolean Satisfiability

Are there true/false values for the variables to make this formula true?

$$(x \vee y \vee z) \wedge (\neg x \vee \neg y) \wedge (\neg z \vee y)$$

[\vee = “or” \wedge = “and” \neg = “not”]

For computer scientists

- Technology-independent foundations of CS.
- How to reason precisely about computation.
- Topics applicable to other parts of CS.

Circuit Design

Parsing + Compiling

Programming

Languages

Program Analysis

+ Synthesis

Artificial Intelligence

Algorithm Design

Databases

Cryptography

Finite Automata

Context-free Languages

Pushdown Automata

Regular Expressions

Formalization in General

Uncomputability

Formal Systems, Logic

Complexity Theory

Formal Representation

+ Reasoning

Complexity Theory

For mathematicians

A “computational perspective” on mathematics.

Ex: which is a ‘better’ formula for the n 'th Fibonacci number (1,1,2,3,5,8,13,21...)?

1.
$$F_n = \frac{1}{\sqrt{5}} \left(\frac{1+\sqrt{5}}{2} \right)^n - \frac{1}{\sqrt{5}} \left(\frac{1-\sqrt{5}}{2} \right)^n .$$

2. $F_n =$ the number of strings over alphabet $\{a, b\}$ of length $n - 2$ with no two consecutive b 's.

Connection between computation and mathematical proofs

- Uncomputability \leftrightarrow Gödel's Incompleteness Theorem.
- P vs. NP \leftrightarrow “are mathematical proofs as easy to find as they are to verify?”
- Can mathematics be automatized?

Important and famous problems for Mathematics

Rich interplay between the Theory of Computation and various areas of mathematics (logic, combinatorics, algebra, number theory, probability, functional analysis, algebraic geometry, topology, ...). Many research opportunities.

For others

- How to recognize and interpret computational intractability in case it appears in your domain, e.g. *PROTEIN FOLDING*, *NEURON TRAINING*, *AUCTION WINNER-DETERMINATION*, *MIN-ENERGY CONFIGURATION OF A GAS*
- How to model computation, e.g. as it may occur in Cells/DNA, the brain, economic systems, physical systems, social networks, ...

Philosophically interesting questions

- Are there well-defined problems that cannot be solved automatically?
- Can we always *always* search for a solution to a puzzle more quickly than trying all possibilities?
- Can we formalize the idea that one problem is “harder” than another?